

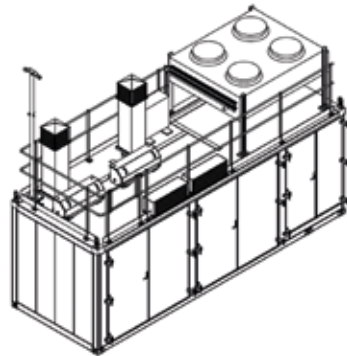

IC50/60 Ionic Compressor

Compressor module for gaseous hydrogen refueling station



Description/application

Based on Linde's Ionic Compressor technology, the IC50/60 is the optimal hydrogen fueling station for larger fleets of heavyweight vehicles like buses or transport trucks with more frequent refueling requirements. It is a highly efficient, reliable and safe fueling station for gaseous hydrogen.

Typical fueling/ station parameters

- Fueling demand: < 900 kg/day
- Number of fuelings: 30/day, 30 kg refueled mass at 350 bar
- Fueling window: 24 hours

Components

- Compressor unit: 2x IC50, 5 stages, hydraulic drive
- Mid-pressure storage: 18 x 550-bar tubes, each with 1,200 liters
- Bank storage management system
- Instrument air supply for valves
- Electric cabinet including air conditioning

Technical data/ performance

- Nominal inlet pressure: 6–201 bara, GH₂
- Outlet pressure: < 500 bar
- Capacity: 56 kg/h
- Power consumption^a: 1–2.8 kWh/kg
- Connection power^b: 186 kW
- Ambient operating temperature: -20 °C / +40 °C
- Noise level: 70 dB (A) at a distance of 10 m
- Footprint (L x W x H): 7 m x 2.4 m x 4.1 m (without chimney)
- Fueling protocol: SAE J 2601-2016
- Certification: CE

^a compressor plus thermal management

^b without H₂ pre-cooling unit

Optional features

- Low-pressure GH₂ storage tank
- F90 fire protection wall
- Parallel fueling
- Additional mid-pressure tubes for GH₂ storage at 550 bar
- Plant monitoring
- Hydrogen pre-cooling unit
- Dispenser for H35 refueling

Linde Hydrogen FuelTech GmbH

Linde Engineering, Erdbergstrasse 197–199, 1030 Vienna, Austria
www.linde-engineering.com

Linde is a company name used by Linde plc and its affiliates. The Linde logo and the Linde word are trademarks or registered trademarks of Linde plc or its affiliates. Copyright © 2021. Linde plc.

